

Double Bits

ASTM F915 Double Bitt

- Custom Coatings Available
- Custom Materials Available

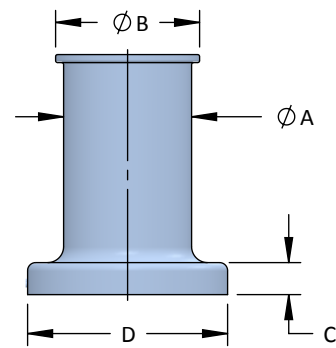
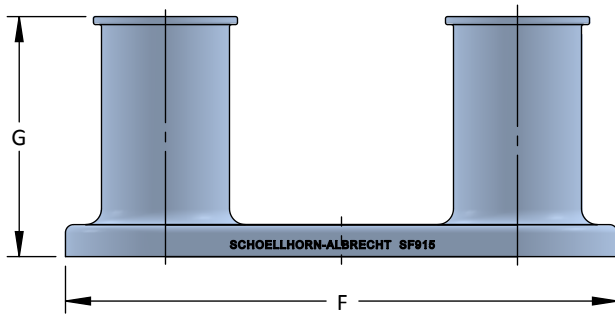
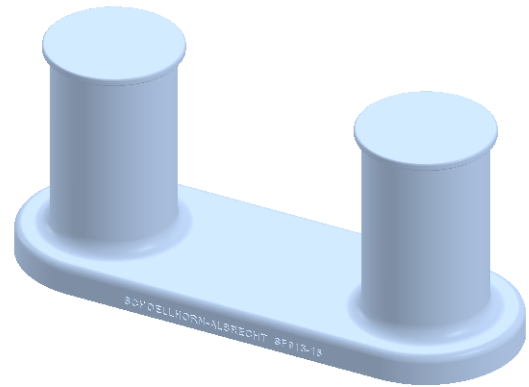
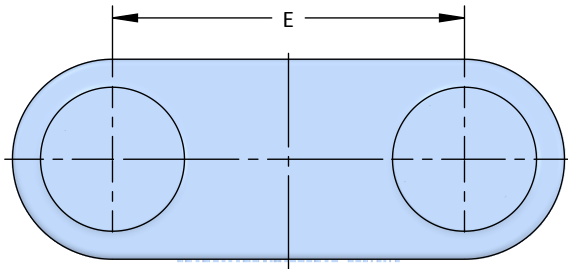

Model No.	SIZE A	B	C	D	E	F	G
SF915-6	6	7 1/2	1 7/8	10	13 1/2	23 1/2	15
SF915-8	8	9 1/2	2 1/4	12	18	30	18
SF915-10	10	11 1/2	2 3/4	16	26	42	21
SF915-12	12	14	3 1/8	20	33	53	24
SF915-14	14	16	3 5/8	22	39	61	27
SF915-16	16	18	4	25	44	69	30
SF915-18	18	20	4 1/2	27	50	77	33
SF915-20	20	22	4 7/8	30	55	85	36
SF915-22	22	25	5 1/8	32	60	92	39
SF915-24	24	27	5 1/2	35	66	101	42

All dimensions are in inches and are subject to change.

