

Double Bitts

ASTM F938 Double Bitt

- Custom Coatings Available
- Custom Materials Available

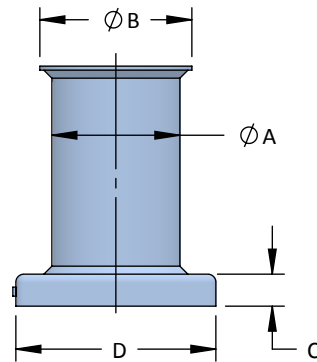
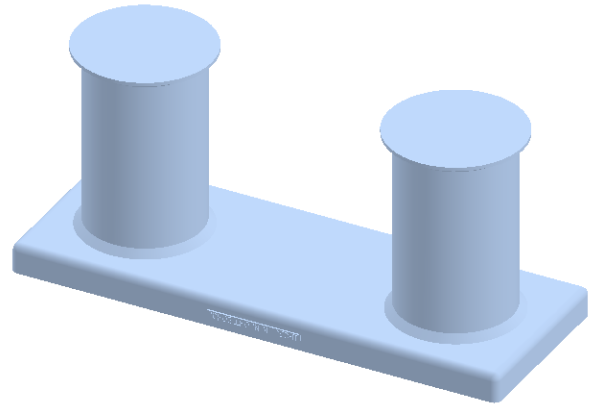
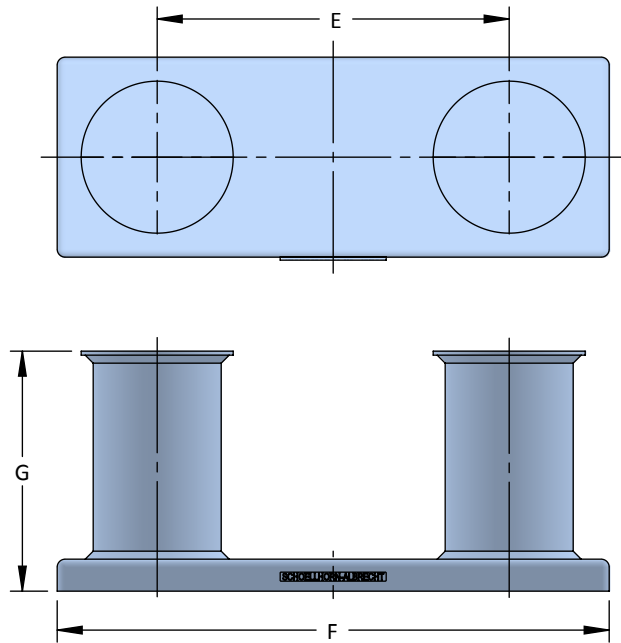

Model No.	NOMINAL SIZE	A	B	C	D	E	F	G
SF938-6	6	6	8	1 ⁷ / ₈	10	13 ¹ / ₂	23 ¹ / ₂	15
SF938-8	8 ⁵ / ₈	8	10	2 ¹ / ₄	12	18	30	18
SF938-10	10	10	12	2 ³ / ₄	16	26	42	21
SF938-12	12 ³ / ₄	12	15	3 ¹ / ₈	20	33	53	24
SF938-14	14	14	17	3 ⁵ / ₈	22	39	61	27
SF938-16	16	16	19	4	25	44	69	30
SF938-18	18	18	21	4 ¹ / ₂	27	50	77	33
SF938-20	20	20	23	4 ⁷ / ₈	30	55	85	36
SF938-22	22	22	25	5 ¹ / ₄	32	60	92	39
SF938-24	24	24	27	5 ¹ / ₂	35	66	101	42

All dimensions are in inches and are subject to change.

